

Diagram C

Proper installation of the cylinder head temperature sender

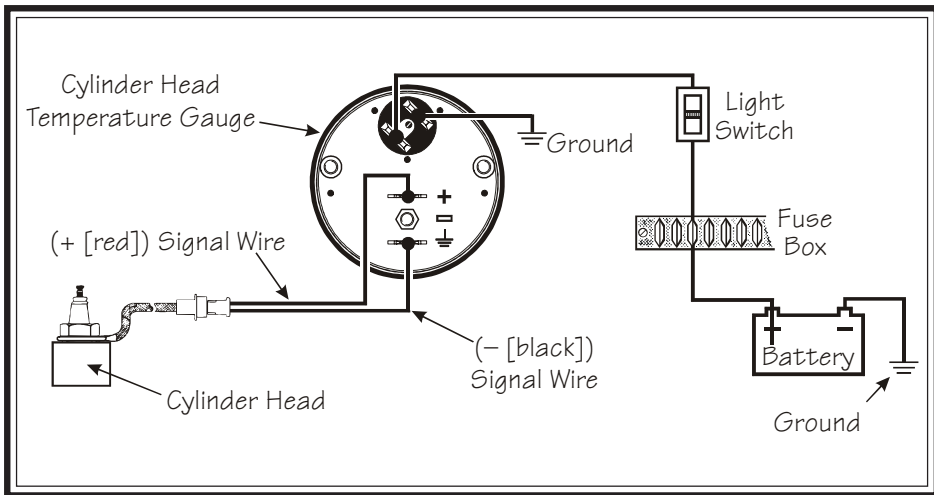

Diagram D

Proper wiring of the Cylinder Head Temperature Gauge

VDO Limited Warranty

VDO North America warrants all merchandise against defects in factory workmanship and materials for a period of 24 months after purchase. This warranty applies to the first retail purchaser and covers only those products exposed to normal use or service. Provisions of this warranty shall not apply to a VDO product used for a purpose for which it is not designed, or which has been altered in any way that would be detrimental to the performance or life of the product, or misapplication, misuse, negligence or accident. On any part or product found to be defective after examination by VDO North America, VDO North America will only repair or replace the merchandise through the original selling dealer or on a direct basis. VDO North America assumes no responsibility for diagnosis, removal and/or installation labor, loss of vehicle use, loss of time, inconvenience or any other consequential expenses. The warranties herein are in lieu of any other expressed or implied warranties, including any implied warranty of merchantability or fitness, and any other obligation on the part of VDO North America, or selling dealer.

(NOTE: This is a "Limited Warranty" as defined by the Magnuson-Moss Warranty Act of 1975.)

VDO North America · 188 Brooke Rd. · P.O. Box 2897 · Winchester, VA 22603 · Phone: 540-665-2428

1 BEGIN HERE

CAUTION: Read these instructions thoroughly before making installation. Do not deviate from assembly or wiring instructions. Always disconnect battery ground before making any electrical connections. If in doubt, please contact your dealer or VDO Instruments at (540) 665-2428.

Gauge Installation:

1. Select the location for the instrument and cut a 2 1/16" hole. (Diagram A)
3. Insert the gauge and secure it with the

[text continues at #2] →

CAUTION!!!

The bezel diameter is only a few millimeters larger than the gauge itself. **With that in mind, measure and precisely mark the gauge location before cutting any holes!**

Tools and Materials Needed For Installation:

- 16 Gauge stranded, insulated wire
- Non-insulated 1/4" spade connectors
- 2 1/16" hole saw
- Drill and drill bit set
- Half-round file
- Tape measure or ruler
- Small tools: wrench or nut driver, utility knife, pliers, etc.

VDO mounting bracket. (Diagram B)
DO NOT OVERTIGHTEN.

Sender Installation:

1. Select the cylinder where you will install the sender. Be sure to carefully follow the manufacturer's specifications.
2. Remove the spark plug.
3. Remove the compression ring from the spark plug.
4. Insert the spark plug through the sender ring and replace the spark plug and sender in the cylinder head (Diagram C). Care should be taken while tightening the spark plug. Do not place the sender wire near any hot engine exhaust components or moving parts.

Parts List

Item	Description	Quantity
1.	Cylinder Head Temperature Gauge (2 1/16" [52 mm] diameter)	1
2.	Lamp Socket (Push in, wedge-type)	1
3.	Light Bulb (12-volt / G.E. #158 or equivalent)	1
4.	VDO Spin-Lok™ Clamp or mounting bracket	1
5.	Installation Instructions	1

VDO® North America

Cylinder Head Temperature Gauge (with sender)

Installation Instructions

Instruction Sheet #0 515 012 130
Rev.03/00

INSTRUCTIONS FOR THE INSTALLATION OF THE ELECTRIC CYLINDER HEAD TEMPERATURE GAUGE ARE CONTAINED HEREIN. USE IS RESTRICTED TO 12-VOLT NEGATIVE GROUND ELECTRICAL SYSTEMS. LIGHT BULB, IF SUPPLIED, IS 12 VOLT.

To Begin, go to #1

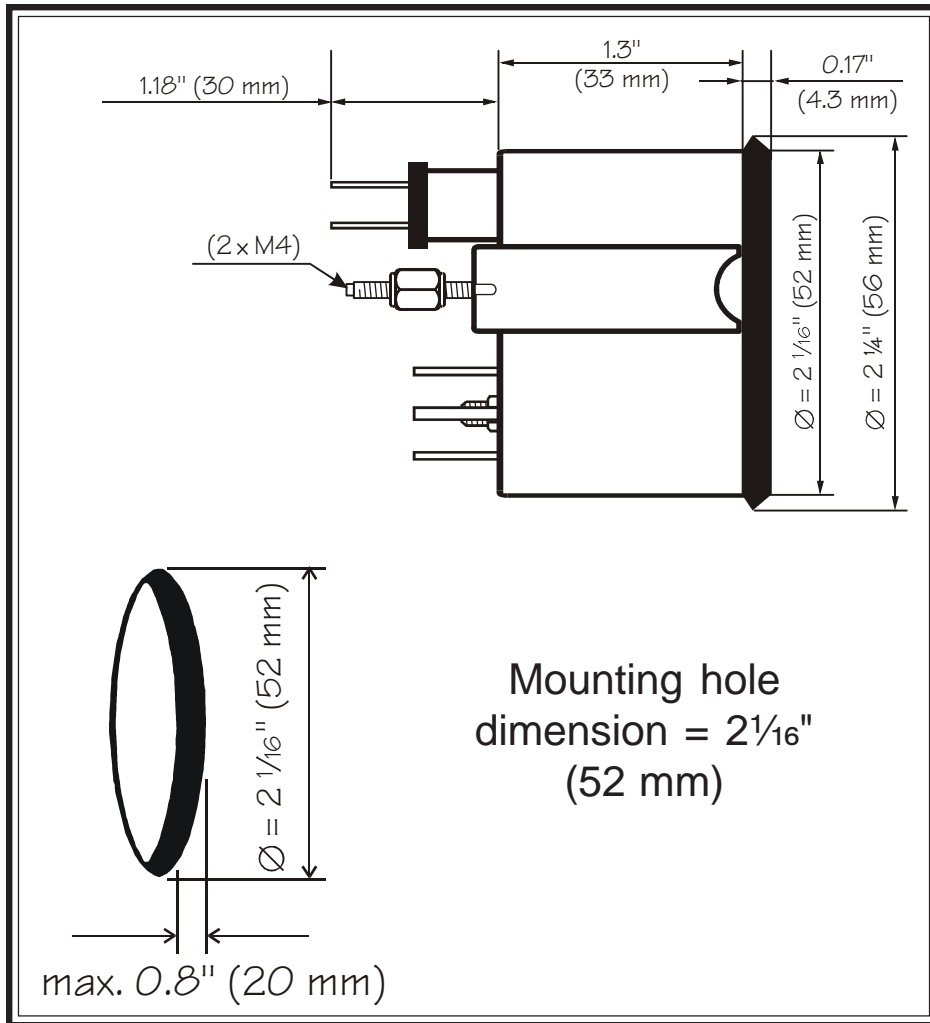

Diagram A
Gauge dimensions

2 CONTINUE HERE

If you must bend the sender, do so as shown in the insert in Diagram C.

NOTE: If your vehicle uses tapered spark plugs, or if the sender won't fit because of a recessed spark plug location, install the sender underneath any accessible head bolt. First put the bolt through a copper washer [large enough to cover the sender ring], then through the sender ring, then into the engine block.

Wiring the Gauge:

1. Run wires (minimum 16-gauge, stranded) from the instrument location through the firewall to:

a) the light switch (after the fuse in the fuse box);

b) a good ground location (i.e., where the negative (-) battery pole is bolted to the chassis of the vehicle);

c) the connector from the sender wire.

2. Run the extension cable (signal wires) from the back of the gauge to the location of the temperature sender.

3. Connect the appropriate positive (+), ground (negative [-]) wires to the gauge and gauge lamp socket as shown in Diagram D.

4. Push together the male and female socket halves (from the back of the gauge and from the sender). Secure any surplus extension wire underneath the dashboard. Avoid crimping the wire.

At this point, installation and wiring are complete. Start the engine to make sure the gauge and gauge light work properly.

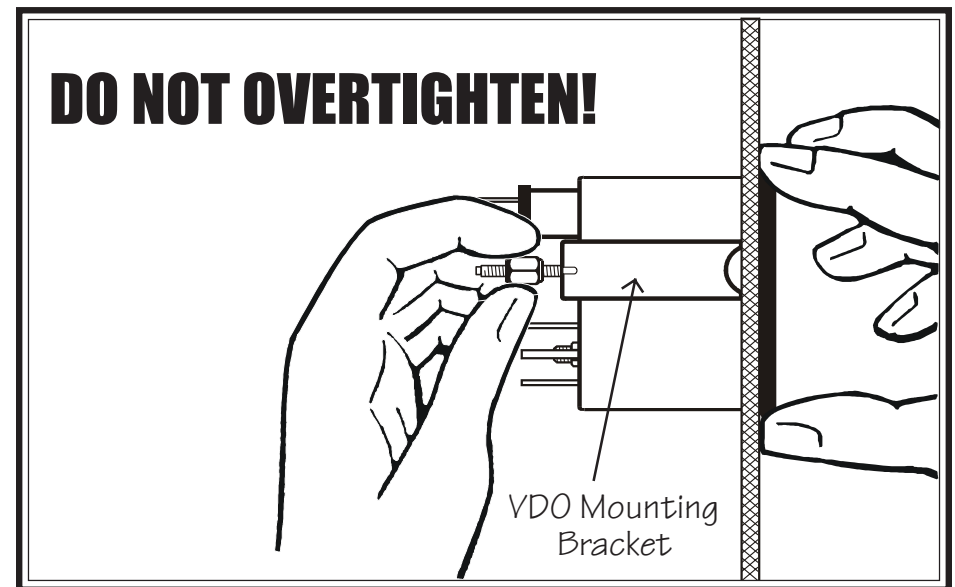

Diagram B
Proper mounting of the Cylinder Head Temperature Gauge